



INSTALLATION GUIDELINES

for

ISO-HT™ POLYISOCYANURATE

MECHANICAL INSULATION

for

**HIGHER TEMPERATURE (Up to 375°F)
APPLICATIONS**

**DYPLAST PRODUCTS
INSTALLATION GUIDELINES
ISO-HT™ POLYISOCYANURATE INSULATION FOR
HIGHER TEMPERATURE (Up to 375°F) APPLICATIONS**

1.0	SCOPE	4
1.1	Applicability	4
1.2	Dyplast References	4
1.3	No Warranty	4
2.0	MATERIALS OF CONSTRUCTION	4
2.1	Insulation Materials for Piping, Fittings, and Valves	4
2.2	Vapor Barrier Sheets and Tape	4
2.3	Mastics, Sealants, and Adhesives	4
3.0	GENERAL	5
3.1	Cleanliness	5
3.2	Shipping/Storage	5
3.3	Testing	5
3.4	Insulation Thickness	5
3.5	Single versus Double Layers	5
3.6	Discoloration	6
3.7	Conflict in Guidance	6
3.8	Pipe Coatings	6
3.9	Flanges	6
3.10	Maintenance Areas	6
3.11	Damaged Insulation	6
3.12	Adjacent Piping	6
4.0	FABRICATION OF INSULATION	7
4.1	Storage Prior to Fabrication	7
4.2	Compliance with ASTM C-450	7
5.0	INSTALLATION OF ISO-HT INSULATION	7
5.1	Apply at Ambient Temperatures	7
5.2	Offset/Stagger Joints	7
5.3	Tightly Align Joints	8
5.4	Butter Joints	8
5.5	Secure Half-Shells	8
5.6	Elbows, Tees, Fittings	8
5.7	Terminations	8
5.8	Valves & Flanges	8
5.9	Pipe Supports	9
5.10	Vertical Piping	9
6.0	APPLICATION OF VAPOR BARRIERS	9
6.1	Necessity for Vapor Barriers	9
6.2	Factory versus Field Applied	9
6.3	Installation with Factory-Applied Vapor Retarders	9
6.4	Installation of Vapor Barriers in the Field	10
6.5	Underground Vapor Barriers	10
6.6	Vapor Barriers on Elbows, Fittings, etc.	10

7.0 CONTRACTION/EXPANSION JOINTS 10

8.0 VAPOR STOPS..... 10

9.0 PROTECTIVE JACKETING MATERIAL 11

9.1 Outdoor Applications 11

9.2 Indoor Applications 12

10.0 TANK, VESSEL, AND EQUIPMENT INSULATION 12

11.0 APPENDICES 14

11.1 APPENDIX A: CORROSION RESISTANT METAL COATINGS 14

11.2 SPECIFIC RECOMMENDATIONS: 14

11.3 APPENDIX B: DETAILS 15

1.0 SCOPE

1.1 Applicability

This guideline covers the installation of ISO-HT Polyisocyanurate Insulation on lower temperature steam (up to 375°F continuous) applications on piping systems, tanks, vessels and equipment. **Due to the variations in service conditions and use, this guideline may not be pertinent for every application, and is not intended to replace the need for a design or specifying engineer to create a specification. A design or specifying engineer should create specifications tailored to particular applications or owner's needs. Such a design or specification engineering service may be more familiar with local conditions, budgets, environment, and desired service life of the system allowing them to generate a precise specification. While supplemental insulation products may be referenced in this guideline, Dyplast recommends consulting the manufacturers of these products for proper fitness-for-duty, installation and handling.**

1.2 Dyplast References

Product data sheets and other Dyplast literature are referenced throughout this guideline. This guideline is subject to revision without notice. Visit www.DyplastProducts.com for the latest version of this document, and other information including physical properties.

1.3 No Warranty

This guideline is offered as a guide for the purposes described herein. No warranty of procedures, either expressed or implied is intended. All other express or implied warranties of merchantability or fitness for a particular purpose are disclaimed.

2.0 MATERIALS OF CONSTRUCTION

2.1 Insulation Materials for Piping, Fittings, and Valves

Insulation should be ISO-HT Polyisocyanurate Insulation, nominally 2.5 lb/ft³ manufactured by Dyplast Products. Contact Dyplast if higher densities are needed for pipe hangars. Test data is available on Dyplast ISO-HT at www.DyplastProducts.com or by calling 305-921-0100.

2.2 Vapor Barrier Sheets and Tape

Vapor barrier sheeting shall be zero-perm DyPerm Wrap, and vapor barrier tape should be zero-perm DyPerm Tape, unless otherwise specified.

2.3 Mastics, Sealants, and Adhesives

In general, solvent and/or water-based joint sealers, mastics, and adhesives may be used in contact with ISO-HT insulation, yet the guidelines of the specific manufacturer and/or the specifier/engineer should be followed. Mastics and sealants should remain flexible across the expected temperature range of the application. Adhesives must be functional at all anticipated temperatures, as well.

Joint sealers for sealing joints of insulation should preferably be a vapor barrier type, with superior moisture and water resistance, unless otherwise specified by the engineer.

Typical joint sealers, adhesives, and mastics from Foster Products/Childers can be accessed and evaluated at either:

<http://www.fosterproducts.com/pdf/InsulationSelectionGuide.pdf> (with Foster brand names),
or

<http://www.fosterproducts.com/pdf/ChildersSelectionGuide.pdf> if you prefer the Childers brand names.

3.0 GENERAL

3.1 Cleanliness

All piping should be free of foreign substances and free of surface moisture or frost prior to the application of insulation.

3.2 Shipping/Storage

All insulation material should be delivered to the project site in original, unbroken factory packaging labeled with product designation and thickness. The shipping package should not be air-tight. Shipment of materials from the manufacturer to the installation location should be in weather-tight transportation. Insulation materials delivered to the job-site should be stored so as to protect the materials from moisture and weather during storage and installation. Insulation material should be protected from sunlight to avoid exposure to UV light from the sun.

3.3 Testing

All testing (including hydrostatic, air pressure, or NDT) of piping and equipment systems should be completed prior to the installation of the insulation system.

3.4 Insulation Thickness

A qualified specifier/engineer should be consulted to ensure the insulation thickness is sufficient to prevent condensation on the outer surface of the insulation system jacketing, and/or to limit the heat gain to a specific value (often 8 Btu/hr-ft² at outer jacketing surface). A number of assumptions must be made, based on application and environmental conditions such as indoor/outdoor application, humidity, wind, cycling, safety factors, and so forth. We recommend that your specifier/engineer work closely with the contractors and Dyplast to help ensure a properly designed, installed, and long-lasting insulation system. Thickness calculations may be performed using the [3E Plus](#) insulation thickness software program that uses heat flow algorithms based on ASTM C680-95. Additionally, at the client's request, Dyplast's certified staff will run basic calculations using 3E Plus if the client provides and takes responsibility for environmental and process inputs.

3.5 Single versus Double Layers

Most insulation systems above ambient and below 375°F require only one layer of ISO-HT insulation, yet the specifier/engineer may require more than one layer.

Where the required insulation thickness is greater than 2 1/2", employ a double layer system. Stagger all longitudinal joints between the inner and outer layers. Install the inner and outer layer longitudinal joints 90° to each other with the inner layer joints in the 12 and 6 o'clock positions and the outer layer joints in the 3 and 9 o'clock positions. All butt joints between the inner and outer layers should be staggered between 6 and 18 inches. Refer to Figure 1 in Appendix B.

3.6 Discoloration

ISO-HT foam insulation may experience a discoloration on the inside surface where it is directly exposed to the pipe surface when the operating temperature is constantly in higher temperature range. This discoloration does not affect the performance of the insulation.

3.7 Conflict in Guidance

Should there be a conflict between this Installation Guide and the specifier/engineer or a system component manufacturer's recommendation (e.g. mastic, adhesive, sealant, vapor barrier), follow the specifier/engineer or the component manufacturer's recommendation as the case may be.

3.8 Pipe Coatings

A pipe coating system may be recommended to minimize the likelihood of pipe corrosion. Consult Appendix A for conditions where pipe coating systems are suggested. Where an anti-corrosion pipe coating system is on a surface to be insulated, drying time should be allotted per the coating manufacturer's recommendation prior to applying the insulation.

3.9 Flanges

All flanges on pipe, ducts and equipment and all valves to the packing gland should be insulated with the same insulation material and thickness as applied to the pipe or equipment unless the engineer indicates otherwise.

On bolted flanges, the permanent insulation on pipe and equipment should terminate 1 inch plus a bolt length from the flange to facilitate bolt removal unless the flange location prevents this spacing.

3.10 Maintenance Areas

Where frequent removal of insulation is required on flanges or equipment, consideration should be given to a removable/reusable cover design.

3.11 Damaged Insulation

Any damaged insulation that may create voids should be replaced with new insulation. Filler material is not acceptable.

3.12 Adjacent Piping

Each pipe should be insulated as a single unit, and adjacent lines should not be enclosed with a common insulation unit, unless approved by the owner's engineer.

4.0 FABRICATION OF INSULATION

4.1 Storage Prior to Fabrication

Store the bun stock at normal shop (indoor) conditions for at least 24 hours before fabrication. This will allow the ISO-HT bun stock to equilibrate to the shop conditions. For best fabrication quality, it is recommended that ISO-HT buns be fabricated into pipe shells in the 36 inch bun length direction to maximize flatness. Fabricated pipe shells with factory-applied vapor barrier should be aged for 24 hours before vapor barrier attachment. Similarly after fabrication of the fittings/elbows/tees, allow the cut pieces to age for 24 hours before factory application of the vapor barrier to the fabricated pieces. After application of vapor barrier, fabricated pipe shells should not be stored for more than one month either in the warehouse or at a job site.

4.2 Compliance with ASTM C-450

Insulation should be fabricated in required shapes from bun stock in accordance with ASTM C-450 “Standard Practice for Prefabrication and Field Fabrication of Thermal Insulating Fitting Covers for NPS Piping, Vessel Lagging, and Dished Head Segments” and C-585 “Standard Practice for Inner and Outer Diameters of Rigid Thermal Insulation for Nominal Sizes of Pipe and Tubing (NPS System)”. Insulation should be factory fabricated by a qualified fabricator from bun stock.

Dyplast recommends that insulation for fittings, such as valves, valve stations, flanges, 90° and 45° elbows, and tees should be two-piece fly-cut or routed as the preferred fabrication method. For diameters too large for fly-cutting or routing, the pieces should be fabricated in two halves with each half made up of mitered sections. Both methods should be in accordance with ASTM C-450 and ASTM C-585.

5.0 INSTALLATION OF ISO-HT INSULATION

5.1 Apply at Ambient Temperatures

ISO-HT insulation should be applied with the piping and component system at ambient temperature, and immediately secured with filament tape.

5.2 Offset/Stagger Joints

ISO-HT foam insulation should be applied using two half-sections to the largest commercially available diameter. For larger sizes curved segments may be utilized.

Begin installing the insulation sections on the pipe with a full length section followed by a half-length section so as to facilitate having no seam adjacent to another seam. The longitudinal joints should typically be at 9 o'clock and 3 o'clock positions.

When additional layers of ISO-HT insulation are required, each should be applied in the same manner as the first layer with circumferential and longitudinal joints staggered between joints of the preceding layers, so that no two joints coincide. For instance, install the inner and outer layer longitudinal joints 90° to each other with the inner layer joints in the 12 and 6 o'clock positions and the outer layer joints in the 3 and 9 o'clock positions. All butt joints between the inner and outer layers should be staggered between 6 and 18 inches.

5.3 Tightly Align Joints

Tightly align all butt as well as longitudinal joints so as to eliminate gaps, except of course as may be appropriate for applications such as expansion joints.

5.4 Butter Joints

Single layer insulation should be applied to piping with all joints sealed full depth with joint sealant and spread to uniform thickness so that joints appear tight and uniform, without excess sealant escaping the joint. In a double layer insulation system, the inner layer should not be installed with sealants unless otherwise specified by the engineer. In double layer systems it is common practice that inner and outer layer remain independent of each other so as to allow movement between the layers.

5.5 Secure Half-Shells

Insulation should be secured with fiber reinforced tape per Figure 4 on 9-inch centers, with such tape also no greater than 3 inches from butt joints.

Where the insulation O.D. is greater than 18 inches $\frac{1}{2}$ inch wide stainless steel bands and seals on 9 inch centers may be preferable, as authorized by the engineer.

5.6 Elbows, Tees, Fittings

Elbow insulation (els) should be routed from ISO-HT insulation to the same thickness as the pipe insulation. Install pre-fabricated insulation fittings on elbows, tees, and valves.

Where it is not possible to use commercially routed insulation els, fabricate the covers using clean cuts and miter counts in accordance with ASTM C450. Secure the half-sectional miters with insulation adhesive and rasp the heal of the miters to accommodate installation of the outer covers.

If a double layer pipe system is required, all fittings should be double layered, with seams/joints offset.

5.7 Terminations

Where the pipe insulation terminates, such as at valves and flanges, seal the exposed insulation by applying two coats of a mastic specified by the engineer, with open weave glass fiber reinforcing cloth between the coats. The total dry film thickness should be per the mastic manufacturer recommendation. Unless otherwise specified by the engineer, the mastic system should cover onto the bare pipe 1 inch minimum and extend over the insulation O.D. a 2 inch minimum from the edge.

5.8 Valves & Flanges

Valves and flanges should be insulated to the same thickness as the pipe insulation using enlarged pipe insulation. The valve and flange covers should extend over the pipe insulation equal in thickness to the pipe insulation or a minimum 2 inches or as otherwise specified.

Fabricate the covers using a high temperature joint adhesive. When the owner requests removable/reusable covers, fabricate them in two pieces with longitudinal seams.

5.9 Pipe Supports

Where the pipe support is directly on the pipe, such as with a clevis type hanger, insulate the hanger in the same manner as a flange. Bottom insulation sections in hanger saddles should have the necessary resistance to compression on pipe diameters 4" and greater. Depending on the saddle length and span chosen for a specific job, lower density insulation such as ISO-HT insulation may be sufficient to be used as saddle insulation. Consult a competent insulation engineer for your specific scenario. Saddles should wrap the insulation in an arc between 120° and 180° depending upon the load.

5.10 Vertical Piping

On vertical piping, to prevent the insulation from sliding down the pipe, install insulation support clamps at the bottom of the vertical run and above flanges with a recommended spacing of 1 inch plus a bolt length unless otherwise specified. The clamps are not necessary where the field team has provided support tabs welded to the pipe.

6.0 APPLICATION OF VAPOR BARRIERS

6.1 Necessity for Vapor Barriers

In constant operating conditions of 250 to 375 degrees F moisture should not be present and a vapor barrier need not be used; however, in temperature cycling systems and where water intrusion is possible from steam wash down or the environment a [DyPerm Wrap](#) (zero perm) vapor barrier is recommended. In applications where a vapor barrier is required, Dyplast recommends that the vapor barrier be factory applied by an authorized fabricator to the outer surface of the pipe insulation.

6.2 Factory versus Field Applied

Vapor barriers may be applied in the field if approved by the engineer given the various factors such as weather, experience of labor, and so forth, but Dyplast recommends that vapor barriers be factory applied by a qualified fabricator.

Vapor barrier film should be cut to length longitudinally and wrapped around the circumference of the pipe with lap joint, and installed facing downward avoiding the placement of the joint at the top or bottom of the pipe. Lap joint should be sealed with either self-sealing tapes or a liquid adhesive. Butt joints should be covered with vapor barrier tape. Spiral wrap configuration can be used in lieu of the above installation. Spiral wrapping will require adhesive placed on one edge of the vapor barrier as it is wrapped over the previous layer.

6.3 Installation with Factory-Applied Vapor Retarders

With factory applied vapor barrier film, the longitudinal lap joint is to be sealed with SSL tape. All vapor barrier surfaces should be cleaned and free of dust/ grease/oil/etc. before application of the SSL tape to ensure good adhesion between the tape and vapor barrier. [DyPerm Tape](#) (zero perm) should be used to circumferentially wrap around and seal the butt joints, with an overlap of 25% (1¼ wraps).

6.4 Installation of Vapor Barriers in the Field

As stated above, solvent or water adhesives may be used to attach the vapor barrier film to the outer surface of the ISO-HT. If DyPerm Wrap is not used as the vapor barrier, refer to the manufacturer's vapor barrier installation guidelines. Consult adhesive manufacturer's literature for instructions on handling adhesives including required operating temperatures. Again refer to the above internet links to evaluate and select the appropriate adhesive.

On field applied vapor barriers, the vapor barrier sheet should overlap itself by either 25% of the circumference, or 3 inches, whichever is less. DyPerm Tape should be used to wrap outside of the vapor retarder at 18" centers with 25% circumferential overlap (1¼ wraps).

Elbows and fittings should be wrapped with vapor barrier tape or covered with a mastic type vapor barrier product. Vapor barrier tape is to be wrapped in a spiral configuration, with a 50% overlap. If using mastic type vapor barrier at fittings and elbows, form mastic so that fitting covers can be applied true and tight.

6.5 Underground Vapor Barriers

Underground vapor barriers should be protected with a metal jacket that is puncture resistant. Underground vapor barriers should be continuous around the pipe and have chemical resistance to expected ground water contaminants.

6.6 Vapor Barriers on Elbows, Fittings, etc.

Elbows and fittings should be wrapped with vapor barrier tape or covered with a mastic type vapor barrier product. Tape is to be wrapped in a spiral configuration with a minimum 50% overlap. If using mastic type vapor barrier at fittings and elbows, form mastic so that fitting covers can be applied true and tight. Contractor should generally not install jacketing with polyurethane foam fill in lieu of a vapor barrier at fittings and elbows without special approval by the engineer.

7.0 CONTRACTION/EXPANSION JOINTS

The location of contraction/expansion joints should be determined by a qualified engineer considering the expected pipe movements.

Contraction/expansion joints in single layer service should be installed as illustrated in Figure 4, or use an approved alternate design. The appropriate designer or engineer must specify the spacing of contraction/expansion joints separately for each system.

Contraction/expansion joints should be filled with a resilient mineral fiber or approve alternate with fibers oriented parallel to the direction of the pipe. The contraction/expansion joint filler should be twice the thickness of the contraction/expansion joint (compressed as tight as possible). Consult with the appropriate engineer to determine the proper contraction/expansion filler material.

8.0 VAPOR STOPS

Vapor stops should be used on either side of valves frequently removed for servicing, valve stations left exposed, or odd fittings, elbows, tees, etc. where the chance of moisture

infiltration is high. Install per detail in Figure 6 in Appendix B or an approved alternate design.

9.0 PROTECTIVE JACKETING MATERIAL

ISO-HT must have a metal jacket that is band secured before turning on the heat/steam. Banding for jacketing should be 0.02" thick by 1/2" wide stainless steel on 9 inch centers. PVC jackets may be used as approved by the engineer. Before metal or PVC jacketing can be installed on a portion of the piping, the vapor barrier system on that portion must be complete and continuous.

9.1 Outdoor Applications

This section covers outdoor areas including, but not limited to, process areas, rooftops and rooftop equipment. ISO-HT Insulation should be protected from prolonged exposure to UV light and weather upon installation. Outdoors, insulation materials with vapor barriers should be covered with a jacketing material within two weeks of installation to eliminate long-term exposure to UV light.

Outdoor jacketing overlap should be a minimum of 2" at butt joints and a minimum of 2" at longitudinal joints. Jacketing should be caulked before closing and banding and positioned in an orientation to avoid water infiltration.

Straight sections of jacketing should be neatly secured with bands and seals with a maximum spacing of 9" on center. End joints should be secured with bands and seals centered directly over joint. Do not use screws, staples or other fasteners on lines containing a vapor barrier system.

For outdoor applications jacketing should be one of the following:

Aluminum

Jacketing should meet ASTM B-209. Consult jacketing manufacturer for recommended thicknesses.

Aluminum jacketing for all fittings, tees, elbows, valves, caps, etc. should be sectional, factory contoured, or field-fabricated to fit closely around insulation.

Banding for jacketing should be specified by the competent engineer, and as a default may be 0.02" thick by 1/2" wide stainless steel on 9 inch centers.

Aluminum protective jacketing should not be considered a vapor barrier.

No fastener capable of penetrating the underlying vapor barrier should be used to secure the aluminum jacket.

Stainless Steel

The material should be of a quality meeting the requirements of ASTM A167 Type 304. Consult jacketing manufacturer for recommended thicknesses.

Banding for jacketing may be 0.02" thick by 1/2" wide stainless steel on 9 inch centers.

Stainless steel protective jacketing is not a vapor barrier.

No fastener capable of penetrating the underlying vapor barrier should be used to secure the stainless steel jacket.

Approved Suppliers include:

- Standard Metal Industries, LLC (at www.smimetal.com)
- RPR Products, Inc. (at www.rprhouston.com)

9.2 Indoor Applications

The minimal thickness recommended for aluminum jacketing installed indoors is 0.016 inches and for stainless steel 0.010 inches

Jacketing may be PVC material where frequent wash-downs are expected, as approved by the engineer. Consult jacketing manufacturer for thickness recommendations. Typical thickness is 0.010 to 0.030 inch. Jacketing should be tough and capable of enduring frequent wash downs with hot water and cleaning agents. All PVC jacket joints should be solvent welded.

Solvent welds eliminate the need for banding over PVC jacketing.

PVC jackets are covered by ASTM C 921 and PVC jacketing temperature should be kept below 150 degrees F.

Supply preformed PVC covers for all fittings, tees, elbows, valves, caps etc. at the same thickness as PVC on straight pipe sections.

10.0 TANK, VESSEL, AND EQUIPMENT INSULATION

All insulation materials should be the same as those used on the pipe associated with the tank, vessel, or equipment.

Tank and vessel head segments should be curved cut to fit in single piece or segments per ASTM C-450. Head segments should be cut so as to eliminate voids at the head section and in a minimum number of pieces so as to eliminate through joints.

Curved segments should be fabricated to fit the contour of the surface in equal size pieces to go around the vessel with a minimum number of through joints. Cutting in the field should be minimized. All sections should be tightly butted and free of voids and gaps.

Vertical vessels greater than 4 feet in diameter require an insulation support ring welded or bolted around the bottom of the tank to prevent the shell insulation from sliding down.

In multi-layer applications, the horizontal and vertical joints of the inner and outer layer curved segments should be staggered (see Figure 8 in Appendix B).

The top of the outer layer of wall insulation in a multi-layer system should be held below the inner layer top a minimum of the insulation thickness. The tank head insulation layers should be cut so as to meet the staggered joint.

Secure the shell insulation with stainless steel bands on 12 inch centers.

In cycling systems or where moisture can be present, Dyplast recommends the use of a factory applied vapor barrier installed by an authorized fabricator. If this is not possible, install vapor barrier film in the field. Tightly wrap the vessel or equipment insulation circumferentially with vapor barrier film. Overlap the seams by a minimum of 2 inches. Seal the overlapped seams with vapor barrier tape. On vertical vessels apply the vapor barrier film starting with the bottom course and work upwards. Each course should overlap on top of the one below it thus providing a joint that will naturally shed water.

The vapor barrier on curved head sections should be mastic/fab/mastic or approved alternate. Flat head sections can be covered with vapor barrier film. Lap joints should be covered with vapor barrier tape.

Legs and appendages attached directly to the shell should be insulated out from the vessel head or wall four times the insulation thickness and the insulation termination sealed with a vapor stop.

On outdoor equipment use aluminum jacketing. Rivets and screws should not be used to attach jacketing on systems using a vapor barrier.

11.0 APPENDICES

11.1 APPENDIX A: CORROSION RESISTANT METAL COATINGS

GENERAL NOTE: Corrosion of metal pipe, vessels, and equipment under insulation, while not typically caused by the insulation, is still a significant issue that must be considered during the design of any mechanical insulation system. The propensity for corrosion is dependent on many factors including the ambient environment and the operating temperature of the metal. The recommendations below represent the general practice in the industry but are not meant to take the place of proper system design and specification by a qualified design engineer familiar with this type of construction. We recommend that the owner consult such an engineer and have them work closely with the fabricator, the contractor, and Dyplast to help insure a properly designed, installed, and long-lasting insulation system free of corrosion.

11.2 SPECIFIC RECOMMENDATIONS:

Stainless Steel All 300 series stainless steel should be coated with an epoxy primer at 5 mil thickness and an epoxy finish coat at 5 mil thickness if operating in a temperature range between 140°F and 375°F or if in a cycling temperature service where the service temperature is between 140° and 375°F for more than 20% of the time. Consult a coating manufacturer for appropriate coating materials and application methods based on the operating temperature range of the equipment.

Carbon Steel All carbon steel operating at a service temperature between 32°F and 375°F or in cycling temperature service where the service temperature is between 32°F and 375°F for more than 20% of the time should be at a minimum primer coated with an epoxy coating. Consult a coating manufacturer for appropriate coating materials and application methods for the operating temperature range of the equipment.

11.3 APPENDIX B: DETAILS

The following details are referenced in the text of this guideline by their Figure numbers. The diagrams included in this section are representative of details used within the industry. However, they are not intended to display the only accepted method of installation but to serve as an example of commonly used and acceptable practices.

Figure 1: DOUBLE LAYERED INSULATION SYSTEM

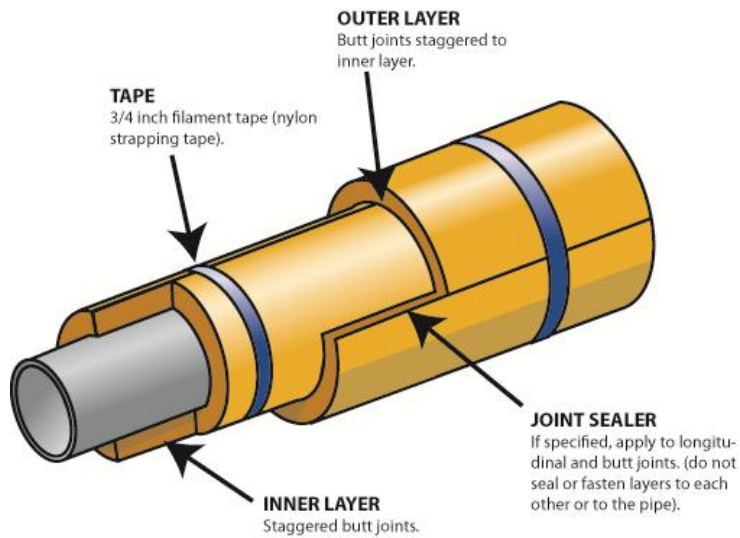
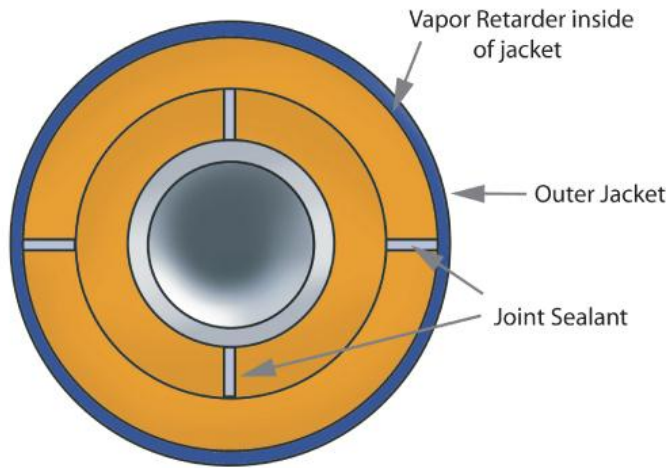

Figure 2: DOUBLE LAYERED SYSTEM, END-VIEW



Notes:

- Inner Layer longitudinal joints at 12 and 6 O'clock. Outer layer joints at 3 and 9 O'clock.
- Stagger half round segments on each layer and between the two layers as shown above.
- The diagram is an example. Joint sealant should be used in accordance with the recommendations of a qualified design engineer.

Figure 3: DOUBLE LAYER ELBOW FITTING

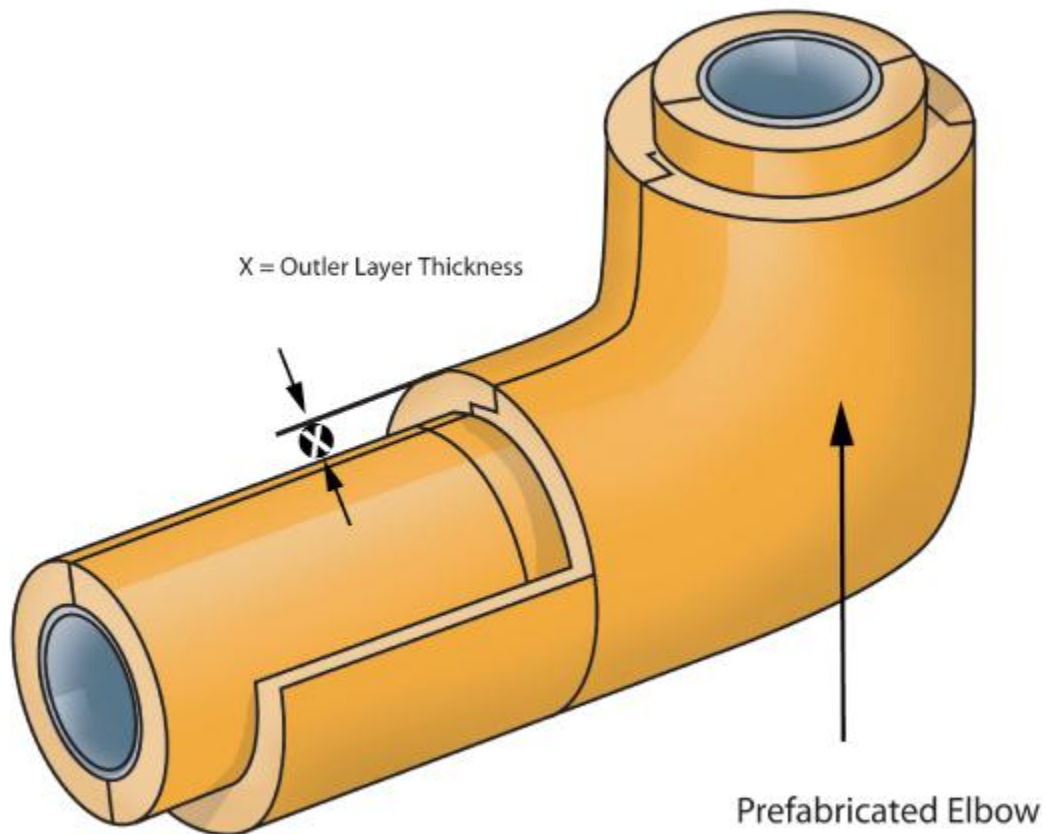

Notes:

- This images shows a shiplap joint end cut to thickness "X" to accommodate double layer pipe insulation. The shiplap necessary only if required by the engineer
- Use in lieu of double layered fittings.
- Wrap elbow with vapor barrier tape.

Figure 4: TAPING PATTERN

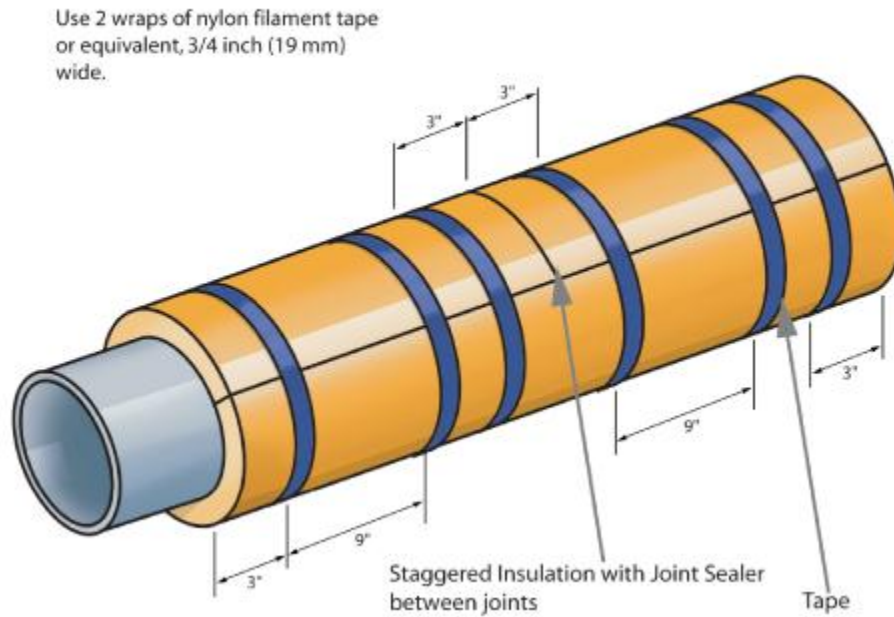

Notes:

- Use two wraps of tape to insure adequate bond.
- Use nylon or glass filament type tape 3/4" wide.

Figure 5: DOUBLE LAYER EXPANSION/CONTRACTION JOINT DETAIL

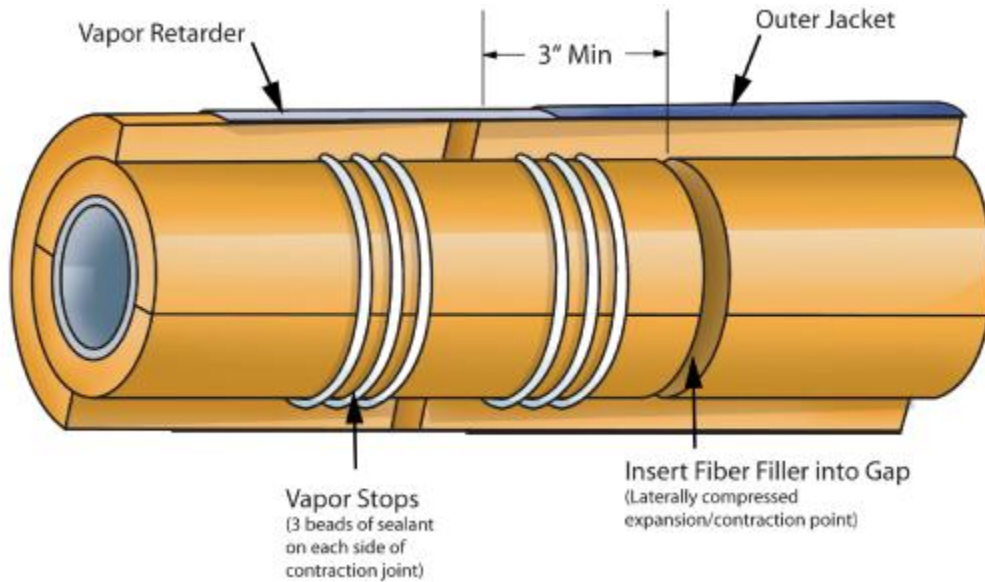

Notes:

- Allow sealant beads to cure prior to installation of outer layer.
- Position outer layer packed glass fiber between sealant dams on inner layer as shown above.
- After glass fiber in contraction joint is installed, insulation sections on either side of contraction joint should be forced together as tightly as possible.

Figure 6: VAPOR STOP DETAILS

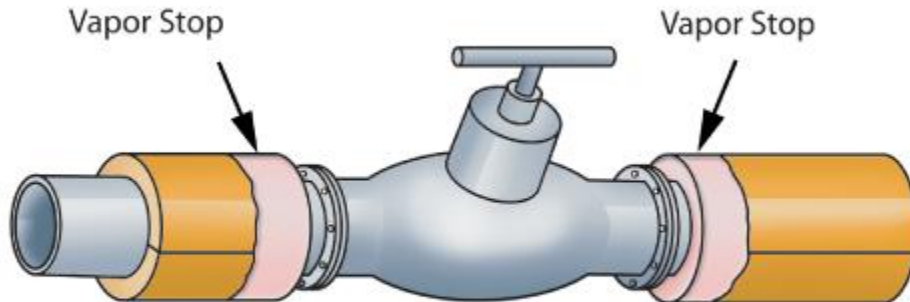

Notes:

- Mastic should be selected based on the service temperature of the system.
- Mastic should be sealed to the pipe face and lapped back over the top of the vapor barrier if fitting is left exposed.

Figure 7: DETAIL OF FACTORY APPLIED VAPOR BARRIER

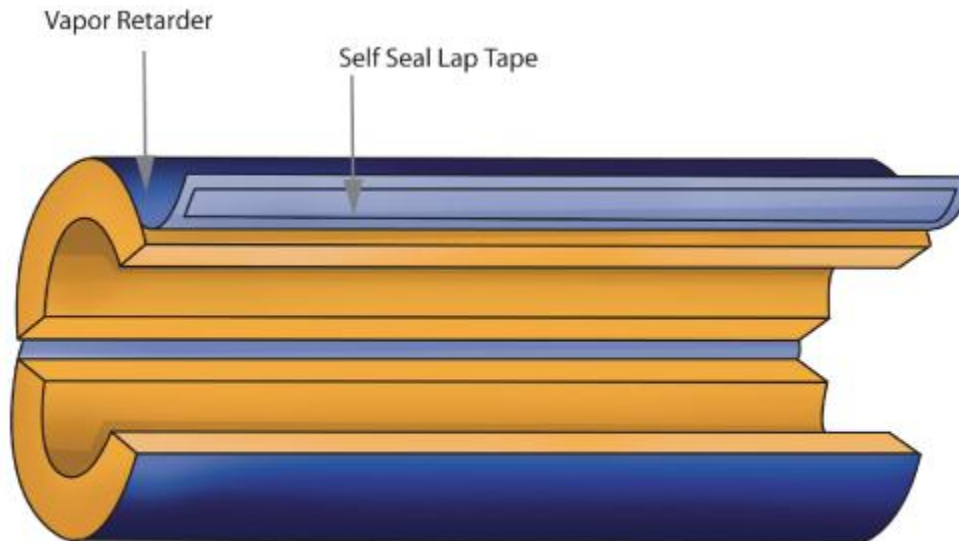

Notes:

- Vapor Barrier can be installed using SSL tape as shown above or using liquid adhesives.
- Butt joints to be covered a minimum of 1.5" on each side of joint by vapor barrier tape or butt strip.

Figure 8: TANK HEAD INSULATION DETAIL

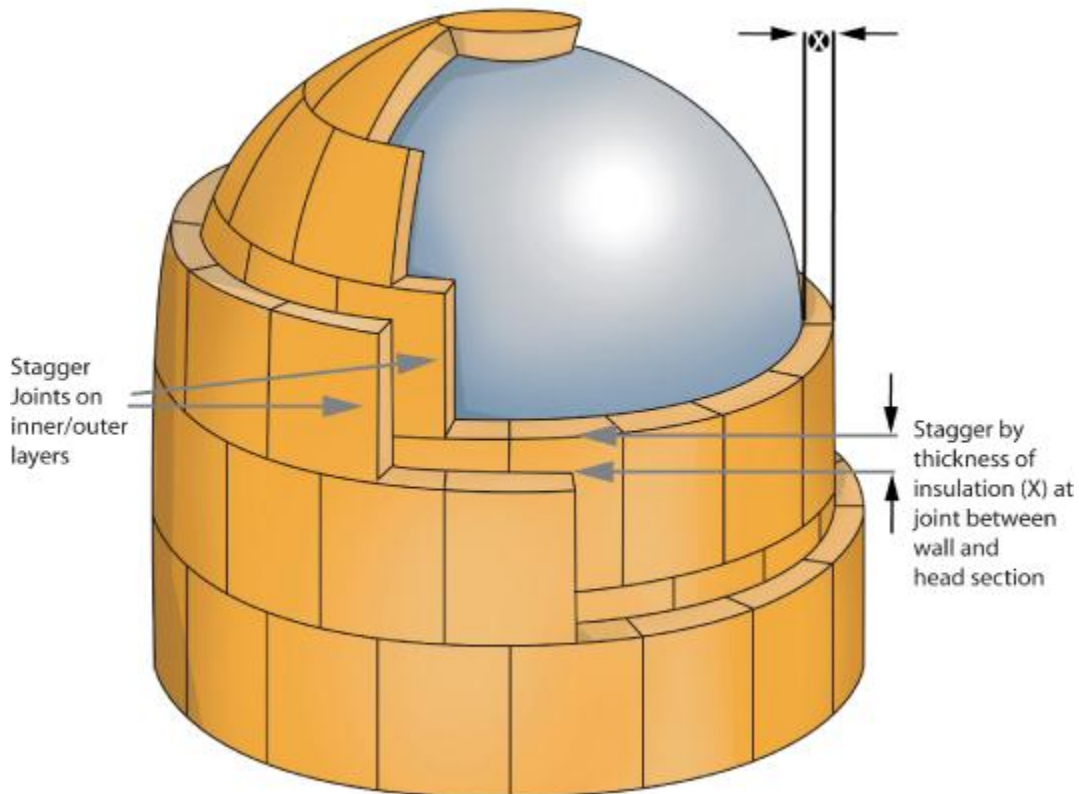

Notes:

- In multiple layer systems, each layer should be installed so that the horizontal and vertical joints in that layer are staggered from the corresponding joints in the preceding layer by half the height or width of a full section.
- At joint between wall and head section, the outer layer should be staggered below the inner layer by the thickness of a single layer.
- Where mastics or sealants are required to bond the insulation sections to the tank head consult the manufacturer's recommendations on service and application temperatures.