

The background of the entire page is a photograph of an industrial facility. It shows a complex network of pipes, some of which are wrapped in white insulation. The pipes are supported by metal brackets and run across a concrete or metal walkway. The lighting is bright, suggesting an outdoor or well-lit indoor environment. The overall color palette is dominated by the metallic grays of the pipes and the white of the insulation, with some blue and yellow accents from the text.

Dyplast products

**DYTHERM INSULATION SYSTEM
INSTALLATION GUIDELINES**

**ISO-C1 RIGID POLYISOCYANURATE
for
LIQUEFIED NATURAL GAS (LNG)
CRYOGENIC
CHILLED WATER
LOW-TEMPERATURE STEAM**



DYPLAST PRODUCTS INSTALLATION GUIDELINES ISO-C1 RIGID POLYISOCYANURATE INSULATION FOR CRYOGENIC, CHILLED WATER, REFRIGERATION AND OTHER LOW-TEMPERATURE APPLICATIONS

1.0	SCOPE	3
1.1	Applicability	3
1.2	Dyplast References	3
1.3	No Warranty	3
2.0	GENERAL	3
2.1	Clean Piping	3
2.2	Shipping/Storage	3
2.3	Testing	3
2.4	Thickness	3
3.0	MATERIALS OF CONSTRUCTION	3
3.1	Insulation Materials for Piping, Fittings, and Valves	3
3.2	Fabrication of Insulation	4
3.3	Adhesives, Joint Sealers and Mastics	4
3.4	Vapor barrier	5
3.5	Contraction/Expansion Joints	5
3.6	Protective Jacketing Material	5
4.0	APPLICATION	6
4.1	Piping – General	6
4.2	Outdoor Piping	7
4.3	Tank, Vessel, and Equipment Insulation	8
5.0	APPENDICES	9
5.1	APPENDIX A: CORROSION RESISTANT METAL COATINGS	9
5.2	APPENDIX B: DETAILS	9
5.3	APPENDIX C: INSULATION THICKNESS	17



1.0 SCOPE

1.1 Applicability

This guideline covers the installation of the DyTherm Insulation System on Liquefied Natural Gas (LNG) piping, tanks, vessels and equipment. The DyTherm System consists of ISO-C1 Rigid Polyisocyanurate Insulation and zero-perm DyPerm Wrap Vapor Barrier film and DyPerm Tape. Due to the variations in service conditions and use, this guideline may not be pertinent for every application. A design or specifying engineer can create specifications tailored to particular applications or owner's needs. Such a design or specification engineering service may be more familiar with local conditions, budgets, environment, and desired service life of the system allowing them to generate a precise specification. While supplemental insulation products may be referenced in this guideline, Dyplast recommends consulting the manufacturers of these products for proper installation and handling.

1.2 Dyplast References

Product data sheets and other Dyplast literature are referenced throughout this guideline. Visit www.DyplastProducts.com for the latest version of these documents. This guideline is subject to revision without notice. Visit www.DyplastProducts.com for the latest version of this document.

1.3 No Warranty

This guideline is offered as a guide for the purpose described herein. No warranty of procedures, either expressed or implied is intended. All other express or implied warranties of merchantability or fitness for a particular purpose are disclaimed.

2.0 GENERAL

2.1 Clean Piping

All piping shall be free of foreign substances and free of surface moisture or frost prior to the application of insulation.

2.2 Shipping/Storage

All insulation material shall be delivered to the project site in original, unbroken factory packaging labeled with product designation and thickness. The shipping package should not be air-tight. Shipment of materials from the manufacturer to the installation location shall be in weather-tight transportation. Insulation materials delivered to the job-site shall be stored so as to protect the materials from moisture and weather during storage and installation. Insulation material shall be protected from sunlight to avoid exposure to UV light from the sun.

2.3 Testing

All testing of piping systems shall be completed prior to the installation of the insulation system.

2.4 Thickness

Refer to insulation thickness charts in Appendix C for recommended insulation thickness based on specific design criteria. For additional insulation thickness calculations utilize the 3E Plus program available at <http://www.pipeinsulation.org>.

3.0 MATERIALS OF CONSTRUCTION

3.1 Insulation Materials for Piping, Fittings, and Valves



- 3.1.1 Insulation shall be ISO-C1 2.0, 2.5, 3.0, 4.0, 6.0, or 10.0 Rigid Polyisocyanurate Insulation manufactured by Dyplast Products.
- 3.1.2 Insulation shall have a maximum aged thermal conductivity of 0.176 BTU-in/hr-ft²-°F (0.025 W/m-°C) at 75°F mean.
- 3.1.3 Applications of 2 lb/ft³ density polyiso requiring Class 1 (ISO-C1/2.0) ratings per ASTM E84 shall have UL classifications and FM specifications and shall have been tested and audited by an independent laboratory.

3.2 Fabrication of Insulation

- 3.2.1 Insulation shall be fabricated in required shapes from bun stock in accordance with ASTM C-450 "Standard Practice for Prefabrication and Field Fabrication of Thermal Insulating Fitting Covers for NPS Piping, Vessel Lagging, and Dished Head Segments" and C-585 "Standard Practice for Inner and Outer Diameters of Rigid Thermal Insulation for Nominal Sizes of Pipe and Tubing (NPS System)". Insulation shall be factory fabricated by a qualified fabricator from bun stock.
- 3.2.2 Dyplast recommends fittings, such as valves, valve stations, flanges, 90° and 45° elbows, and tees shall be two piece flycut or routed as the preferred fabrication method. For diameters too large for flycutting or routing, the pieces shall be fabricated in two halves with each half made up of mitered sections. Both methods shall be in accordance with ASTM C-450 and ASTM C-585. Refer to applications sections 4.1.6 and 4.1.7 for related additional information.
- 3.2.3 Store the bun stock at normal shop (indoor) conditions for at least 24 hours before fabrication. This will allow the ISO-C1 bun stock to equilibrate to the shop conditions. For best fabrication quality, it is recommended that ISO-C1 buns be fabricated into pipe shells in conveyor direction (length direction) to maximize flatness. Fabricated pipe shells with factory-applied vapor barrier shall be aged for 24 hours before vapor barrier attachment. Similarly after fabrication of the fittings/elbows/tees, allow the cut pieces to age for 24 hours before factory application of the vapor barrier to the fabricated pieces. After application of vapor barrier, fabricated pipe shells shall not be stored for more than one month either in the warehouse or at a job site.

3.3 Adhesives, Joint Sealers and Mastics

- 3.3.1 Solvent based adhesives, joint sealers and mastics may be used in contact with ISO-C1 insulation. Mastics shall remain flexible at the lowest expected ambient temperature.
- 3.3.2 Joint sealers for sealing joints of insulation shall be vapor barrier type, moisture and water resistant, non hardening, and flexible with a service temperature range from -275°F to +200°F.
- 3.3.3 A vapor barrier type joint sealer shall be applied on insulation longitudinal joints and butt joints to prevent moisture and moisture vapor infiltration. Such joint sealers are Fosters 95-50 sealer or approved equal. Please consult joint sealer manufacturer for recommended products
- 3.3.4 Solvent or water adhesives may be used to attach the vapor barrier to the outer surface of the ISO-C1. Refer to the vapor barrier installation guidelines. Consult adhesive manufacturer's literature for instructions on handling adhesives including required operating temperatures. Potential adhesives for use in this application include:
 - a) Childers CP 88 adhesive (solvent based)
 - b) Foster 81-05 adhesive (solvent based)
 - c) Foster 85-50 adhesive (water based)



d) Foster 85-60 adhesive (water based)

3.4 Vapor barrier

- 3.4.1 A double layer vapor barrier design shall be used for LNG applications. The secondary vapor barrier shall be applied between the outer most foam insulation layer and the next inner layer of foam insulation. A primary vapor barrier shall be applied to the outer most foam insulation layer. Refer to Figure 2 in Appendix B for details.
- 3.4.2 Vapor barrier film should be factory applied by an authorized fabricator to the outer surface of pipe insulation.
- 3.4.3 Vapor barrier shall be zero-perm DyPerm Wrap laminated vapor barrier film for pipe Insulation, or equivalent. Refer to ASTM standards C-755 and C-1136 for information on selection and specification of vapor barriers. Refer to product literature and installation guidelines from the vapor barrier manufacturer for recommended application instructions.
- 3.4.4 Vapor barrier tape shall be zero-perm DyPerm Tape.
- 3.4.5 Elbows and fittings shall be wrapped with vapor barrier tape with a 50% overlap.
- 3.4.6 Vapor barrier film and tape shall have a maximum permeance of 0.00 perm-in.
- 3.4.7 Consult manufacturer's literature and installation guidelines.
- 3.4.8 For tanks, vessels, and equipment, use similar Vapor barrier Films or approved equal.

3.5 Contraction/Expansion Joints

- 3.5.1 The location of contraction/expansion joints should be determined considering the expected pipe movements.
- 3.5.2 Contraction/expansion joints should be installed in the inner insulations layers of the horizontal piping and equipment.
- 3.5.3 The joints should be installed at maximum intervals of 20 feet. Consult with the appropriate engineer to determine the proper spacing of the contraction/expansion joints for each system.
- 3.5.4 Contraction/expansion joints should be filled with a resilient mineral fiber or approve alternate with fibers oriented parallel to the direction of the pipe. The contraction/expansion joint filler should be twice the thickness of the contraction/expansion joint (compressed to _ the thickness). Consult with the appropriate engineer to determine the proper contraction/expansion filler material.

3.6 Protective Jacketing Material

Shall be one of the following:

A) Aluminum Sheet

- Jacketing shall be aluminum alloys 3003, 1100 or 3105, H-14 temper, meeting ASTM B-209. Use white painted aluminum jacketing for all outdoor applications. Consult jacketing manufacturer for recommended thicknesses. Typical thickness is 0.016" (up to 24" pipe) and 0.024" (> 24" pipe size).
- Aluminum jacketing for all fittings, tees, elbows, valves, caps, etc. shall be sectional, factory contoured, or field-fabricated to fit closely around insulation.
- Banding for jacketing shall be 0.02" thick by 1/2" wide stainless steel.
- Aluminum protective jacketing shall not be considered a vapor barrier. See section 3.4 for vapor barrier recommendations.
- No fastener capable of penetrating the underlying vapor barrier shall be used to secure the aluminum jacket.

- B) Stainless Steel
 - The material shall be of a quality meeting the requirements of ASTM A167 Type 304. Use white painted stainless steel jacketing for all outdoor applications. Consult jacketing manufacturer for recommended thicknesses.
 - Banding for jacketing shall be 0.02" thick by 1/2" wide stainless steel.
 - Stainless steel protective jacketing shall not be considered a vapor barrier. See section 3.4 for vapor barrier recommendations.
 - No fastener capable of penetrating the underlying vapor barrier shall be used to secure the stainless steel jacket.
- C) Approved Suppliers include:
 - Standard Metal Industries, LLC (at www.smimetal.com)
 - RPR Products, Inc. (at www.rprhouston.com)

4.0 APPLICATION

4.1 Piping – General

- 4.1.1 Most chill water/refrigerant systems require only one layer of ISO-C1 insulation, yet the specifier/engineer may require more than one layer.
- 4.1.2 All piping, operating at cryogenic/LNG temperatures, requiring 5" or more of insulations shall be applied in three layers, comprising an inner, middle, and outer layer of ISO-C1 insulation. See Table1 in Appendix B for details.
- 4.1.3 All piping, operating at cryogenic/LNG temperatures, requiring less than 5" of insulations shall be applied in two layers, comprising of an inner and outer layer of ISO-C1 insulation. See Table 1 in Appendix B for details.
- 4.1.4 Stagger all longitudinal joints between the inner and outer layers. Install the inner and outer layer longitudinal joints 90° to each other with the inner layer joints in the 12 and 6 o'clock positions and the outer layer joints in the 3 and 9 o'clock positions. All butt joints between the inner and outer layers shall be staggered between 6 and 18 inches. Refer to Figure 1 in Appendix B.
- 4.1.5 Where insulation thickness required is greater than 5", utilize a triple layer system. Stagger all longitudinal joints between the inner, middle, and outer layers. Install the inner, middle, and outer layer longitudinal joints 90° to each other with the inner layer joints in the 3 and 9 o'clock positions, the middle layer joints in the 12 and 6 o'clock positions, and the outer layer joints in the 3 and 9 o'clock positions. All butt joints between the inner, middle and outer layers shall be staggered between 6 and 18 inches. Refer to Figure 2 in Appendix B.
- 4.1.6 Dyplast recommends insulation shall be fabricated with shiplap or tongue and groove longitudinal joints and shiplap ends.
- 4.1.7 Install pre-fabricated insulation fittings on elbows, tees, and valves. Insulation shall be the same thickness as pipe sections and fabricated with shiplap ends and shiplap or tongue and groove longitudinal joints. Refer to Figure 3 in Appendix B
- 4.1.8 In a triple layer insulation system, the inner layer shall not be installed with sealants. In triple layer systems the inner, middle and outer layer shall remain independent of each other so as to allow movement between the layers.
- 4.1.9 In double layer insulation system, inner layer shall not be installed with sealants. In double layer systems the inner and outer layer shall remain independent of each other to allow movement between the layers. Refer to Figure 1 in appendix B.

- 4.1.10** Insulation shall be secured to the pipe with 3/4" wide fiber reinforced tape. Tape shall be applied as per Figure 4 in Appendix B.
- 4.1.11** Insulation shall be secured with fiber reinforced tape on both inner and outer layers of a multi layered systems except as noted in section 4.1.13.
- 4.1.12** Outer layer insulation and vapor barrier shall be secured with fiber reinforced tape. Use a 25% circumferential overlap on 12" centers when vapor barrier is factory applied to insulation. Fiber tape shall be applied to the exterior of the insulation/vapor barrier system.
- 4.1.13** Contraction/expansion joints shall be installed as described in section 3.5 and illustrated in Figure 5 in Appendix B or approved alternate design. The appropriate designer or engineer must specify the spacing of contraction/expansion joints separately for each system.
- 4.1.14** All insulation shall be tightly butted and free of voids and gaps at all joints. Vapor barrier must be continuous. All fasteners and bands shall be neatly aligned and overall work must be of high quality appearance and workmanship.
- 4.1.15** Vapor stops shall be used on either side of valves frequently removed for servicing, valve stations left exposed, or odd fittings, elbows, tees, etc. where the chance of moisture infiltration is high. Install per detail in Figure 6 in Appendix B or an approved alternate design.
- 4.1.16** When using ISO C1 products in a chilled water, cryogenic, LNG, or refrigerant application as part of an insulation system with a vapor barrier, Dyplast recommends that the vapor barrier be factory applied by an authorized fabricator to the outer surface of the pipe insulation. The vapor barrier shall have a maximum permeance of 0.00 perm and shall be DyPerm Wrap or equivalent.
- 4.1.17** Vapor barrier Film should be cut to length longitudinally and wrapped around the circumference of the pipe with lap joint and installed facing downward avoiding the placement of the joint at the top or bottom of the pipe. Lap joint to be sealed using liquid adhesive. Butt joints shall be covered with Vapor barrier Tape. Spiral wrap configuration can be used in lieu of the above installation. Spiral wrapping will require adhesive placed on one edge of the vapor barrier as it is wrapped over the previous layer.
- 4.1.18** Elbows and fittings shall be wrapped with DyPerm Tape vapor barrier tape or covered with a mastic type vapor barrier product. Vapor barrier Tape is to be wrapped in a spiral configuration. If using mastic type vapor barrier at fittings and elbows, form mastic so that fitting covers can be applied true and tight.
- 4.1.19** On factory applied Vapor barrier Film, lap joint to be sealed with SSL tape. All vapor barrier surfaces should be cleaned and free of dust, grease, oil, etc before application of the SSL tape to ensure good adhesion between the tape and vapor barrier. Refer to Figure 7 in Appendix. For other types of factory applied vapor barriers, consult manufacturer's recommendations on installation.
- 4.1.20** Before jacketing can be installed on a portion of the piping, the vapor barrier system on that portion must be complete and continuous.
- 4.1.21** It is good engineering practices to coat the pipes in LNG applications. Consult Appendix A for conditions where pipe coating systems are suggested.

4.2 Outdoor Piping

- 4.2.1** This section covers outdoor areas including, but not limited to, process areas, rooftops and rooftop equipment.

- 4.2.2 ISO-C1 Insulation shall be protected from prolonged exposure to UV light and weather upon installation.
- 4.2.3 Outdoors, insulation materials shall be covered with a jacketing material within two weeks of installation to eliminate long-term exposure to UV light.
- 4.2.4 Refer to section 3.6 for material specification on outdoor jacketing.
- 4.2.5 Outdoor jacketing overlap shall be a minimum of 2" at butt joints and a minimum of 2" at longitudinal joints. Jacketing shall be caulked before closing and banding and positioned in an orientation to avoid water infiltration.
- 4.2.6 Straight sections of jacketing shall be neatly secured with bands and seals with a maximum spacing of 9" on center. End joints shall be secured with bands and seals centered directly over joint. Do not use screws, staples or other fasteners on lines containing a vapor barrier system.

4.3 Tank, Vessel, and Equipment Insulation

- 4.3.1 All insulation materials shall be the same as those used on the pipe associated with the tank, vessel, or equipment.
- 4.3.2 Tank and vessel head segments shall be curved cut to fit in single piece or segments per ASTM C-450. Head segments shall be cut so as to eliminate voids at the head section and in a minimum number of pieces so as to eliminate through joints.
- 4.3.3 Curved segments shall be fabricated to fit the contour of the surface in equal size pieces to go around the vessel with a minimum number of through joints. Cutting in the field shall be minimized. All sections shall be tightly butted and free of voids and gaps.
- 4.3.4 Vertical vessels greater than 4 feet in diameter require an insulation support ring welded or bolted around the bottom of the tank to prevent the shell insulation from sliding down.
- 4.3.5 Seal all outer layer and single layer butt joints with joint sealer. Refer to section 3.3.
- 4.3.6 In multi layer applications, the horizontal and vertical joints of the inner and outer layer curved segments shall be staggered (see Figure 8 in Appendix B).
- 4.3.7 The top of the outer layer of wall insulation in a multi layer system shall be held below the inner layer top a minimum of the insulation thickness. The tank head insulation layers shall be cut so as to meet the staggered joint.
- 4.3.8 Secure the shell insulation with stainless steel bands on 12 inch centers.
- 4.3.9 Dyplast recommends vapor barrier be factory applied by an authorized fabricator. If this is not possible, install Vapor barrier Film. Tightly wrap the vessel or equipment insulation circumferentially with vapor barrier film. Overlap the seams by a minimum of 2 inches. Seal the overlapped seams with vapor barrier tape. On vertical vessels apply the vapor barrier film starting with the bottom course and work upwards. Each course should overlap on top of the one below it thus providing a joint that will naturally shed water.
- 4.3.10 The vapor barrier on curved head sections shall be mastic/fab/mastic or approved alternate. Flat head sections can be covered with vapor barrier film. Lap joints shall be covered with Vapor barrier Tape.
- 4.3.11 Legs and appendages attached directly to the shell shall be insulated out from the vessel head or wall four times the insulation thickness and the insulation termination sealed with a vapor stop.

- 4.3.12 On outdoor equipment use aluminum jacketing per section 3.5. Rivets and screws shall not be used to attach jacketing on systems using a vapor barrier.

5.0 APPENDICES

5.1 APPENDIX A: CORROSION RESISTANT METAL COATINGS

5.1.1 GENERAL NOTE: Corrosion of metal pipe, vessels, and equipment under insulation, while not typically caused by the insulation, is still a significant issue that must be considered during the design of any mechanical insulation system. The propensity for corrosion is dependent on many factors including the ambient environment and the operating temperature of the metal. The recommendations below represent the general practice in the industry but are not meant to take the place of proper system design and specification by a qualified design engineer familiar with this type of construction. We recommend that the owner consult such an engineer and have them work closely with the fabricator, the contractor, and Dyplast to help insure a properly designed, installed, and long-lasting insulation system free of corrosion.

5.1.2 SPECIFIC RECOMMENDATIONS:

5.1.2.1 Stainless Steel All 300 series stainless steel shall be coated with an epoxy primer at 5 mil thickness and an epoxy finish coat at 5 mil thickness if operating in a temperature range between 140°F and 300°F or if in a cycling temperature service where the service temperature is between 140° and 300°F for more than 20% of the time. Consult a coating manufacturer for appropriate coating materials and application methods based on the operating temperature range of the equipment.

5.1.2.2 Carbon Steel All carbon steel operating at a service temperature between 32°F and 300°F or in cycling temperature service where the service temperature is between 32°F and 300°F for more than 20% of the time shall be at a minimum primer coated with an epoxy coating. Consult a coating manufacturer for appropriate coating materials and application methods for the operating temperature range of the equipment.

5.2 APPENDIX B: DETAILS

The following details are referenced in the text of this guideline by their Figure numbers. The diagrams included in this section are representative of details used within the industry. However, they are not intended to display the only accepted method of installation but to serve as an example of commonly used and acceptable practices.

Figure 1: DOUBLE LAYERED INSULATION SYSTEM

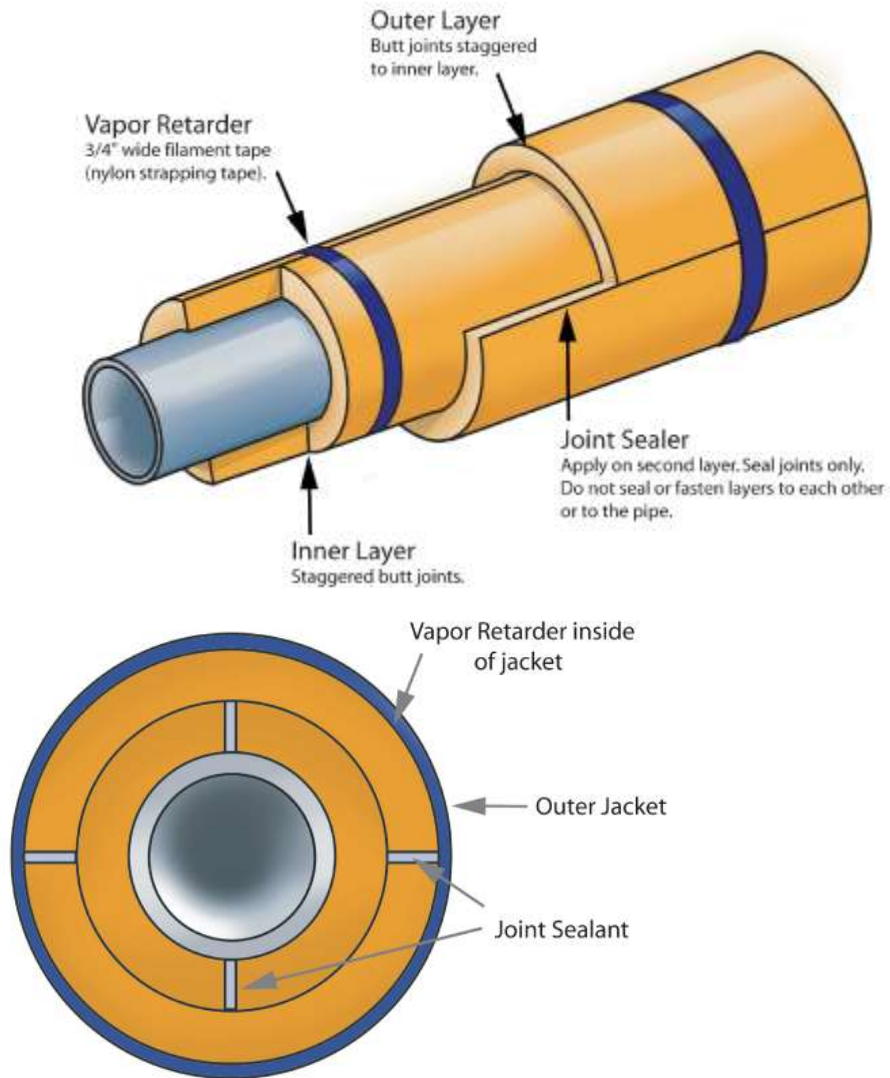

Notes:

- Inner Layer longitudinal joints at 12 and 6 O'clock. Outer layer joints at 3 and 9 O'clock.
- Stagger half round segments on each layer and between the two layers as shown above.
- Use thin coat of sealant over whole joint depth. Butter excess down the face of the joint. Use sealant on outer layer only.

Figure 2: TRIPLE LAYERED INSULATION SYSTEM

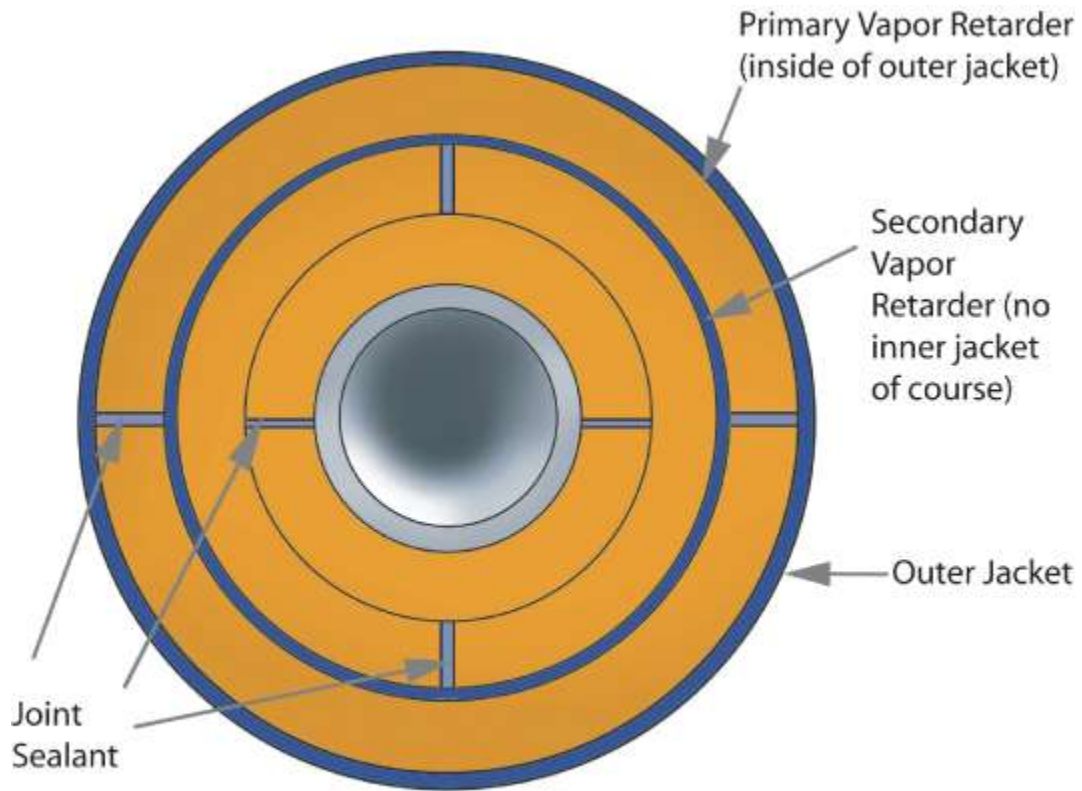
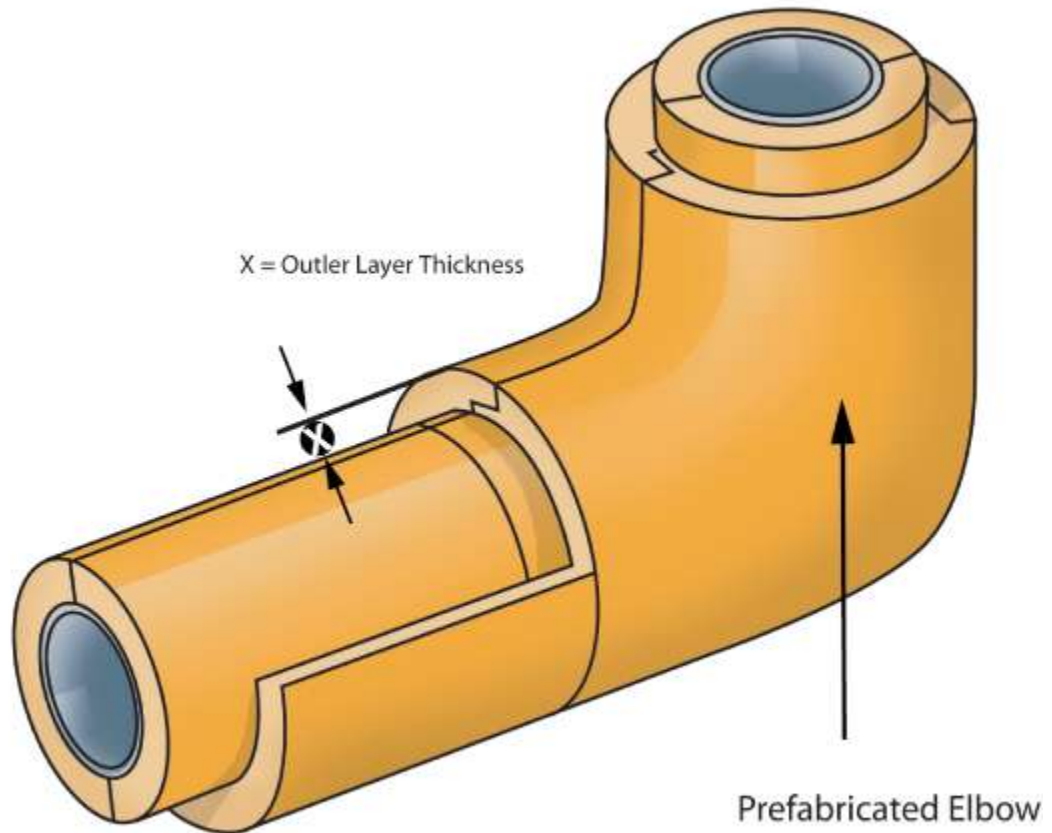

Figure 3: FULL THICKNESS SHIPLAP ELBOW FITTING



Notes:

- Shiplap end cut to thickness "X" to accommodate double layer pipe insulation.
- Use in lieu of double layered fittings.
- Wrap elbow with Vapor barrier Tape.

Figure 4: TAPING PATTERN

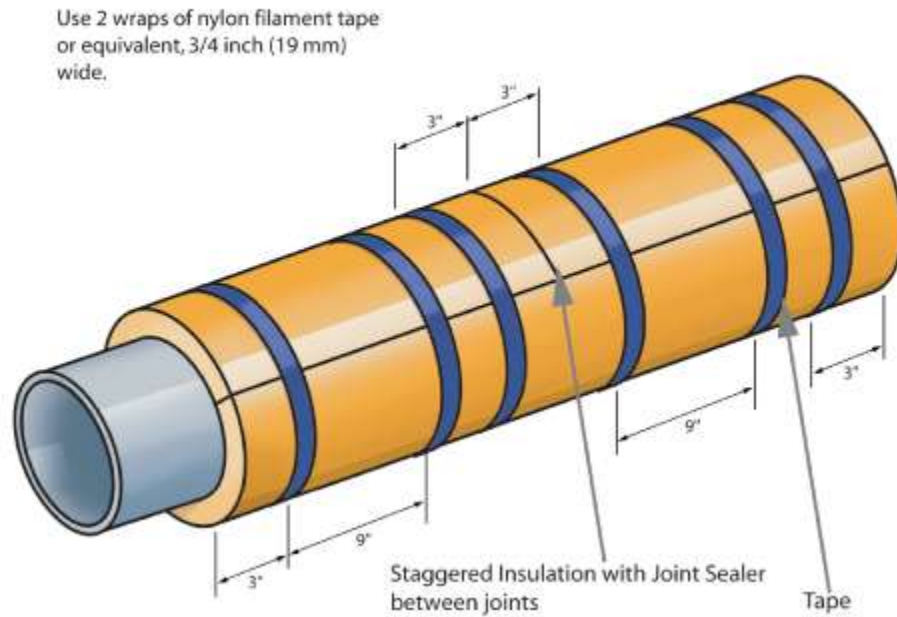

Notes:

- Use two wraps of tape to insure adequate bond.
- Use nylon or glass filament type tape 3/4" wide.

Figure 5: DOUBLE LAYER EXPANSION/CONTRACTION JOINT DETAIL

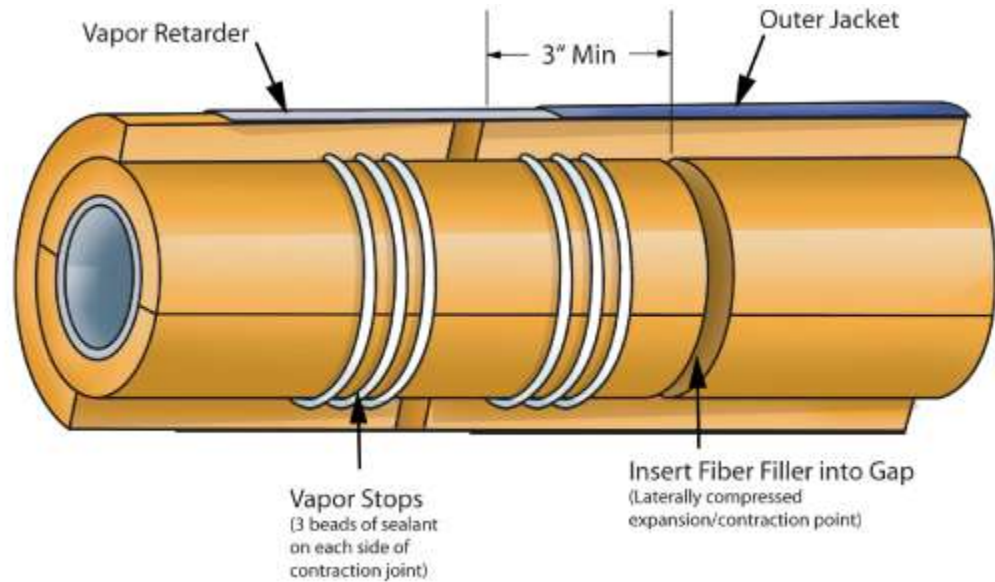

Notes:

- Allow sealant beads to cure prior to installation of outer layer.
- Position outer layer packed glass fiber between sealant dams on inner layer as shown above.
- After glass fiber in contraction joint is installed, insulation sections on either side of contraction joint shall be forced together as tightly as possible.

Figure 6: VAPOR STOP DETAILS



Notes:

- Mastic should be selected based on the service temperature of the system.
- Mastic shall be sealed to the pipe face and lapped back over the top of the vapor barrier if fitting is left exposed.

Figure 7: DETAIL OF FACTORY APPLIED VAPOR BARRIER

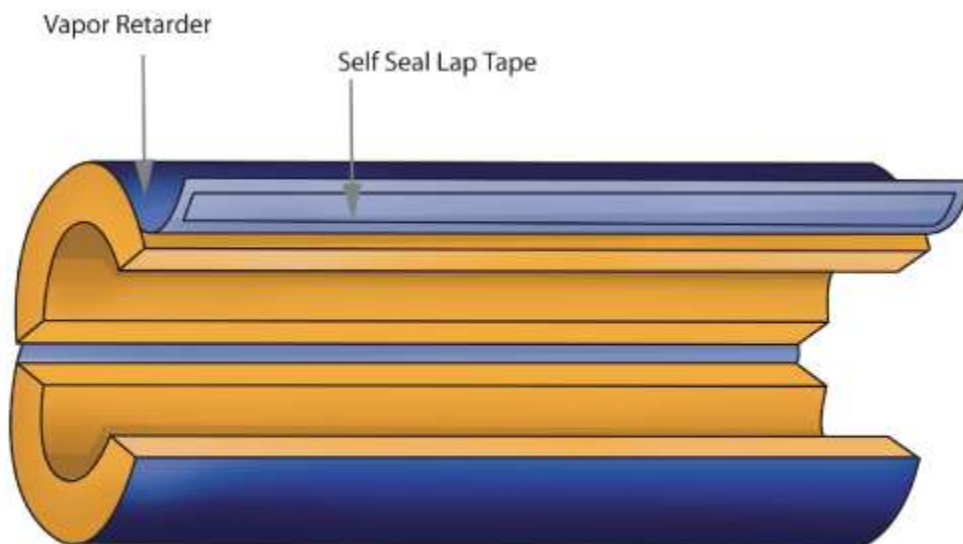

Notes:

- Vapor Barrier can be installed using SSL tape as shown above or using liquid adhesives.
- Butt joints to be covered a minimum of 1.5" on each side of joint by vapor barrier tape or butt strip.

Figure 8: TANK HEAD INSULATION DETAIL

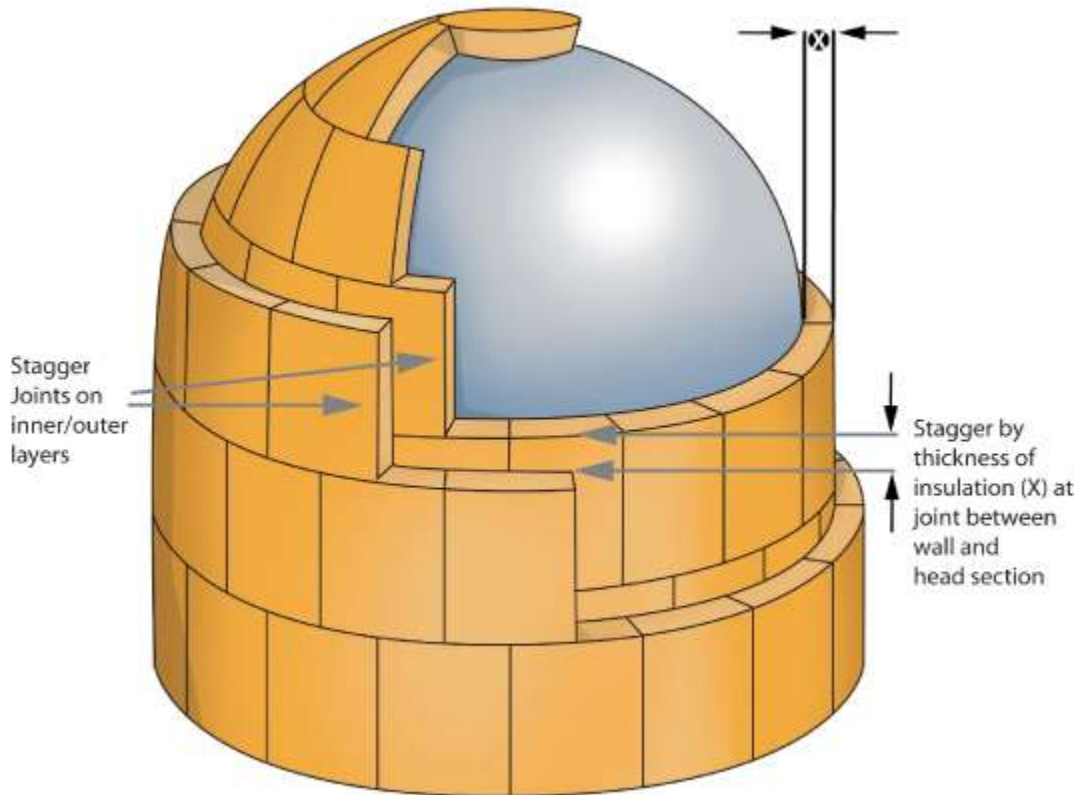

Notes:

- In multiple layer systems, each layer shall be installed so that the horizontal and vertical joints in that layer are staggered from the corresponding joints in the preceding layer by half the height or width of a full section.
- At joint between wall and head section, the outer layer shall be staggered below the inner layer by the thickness of a single layer.
- Where mastics or sealants are required to bond the insulation sections to the tank head consult the manufacturer's recommendations on service and application temperatures.



5.3 APPENDIX C: INSULATION THICKNESS

The client's engineer should be consulted to ensure the insulation thickness necessary to prevent condensation on the outer surface of the insulation system jacketing. In a few cases, the thickness must also ensure the insulation thickness necessary to limit the heat gain to a specific value (usually 8 btu/hr-ft² of outer jacketing surface). A number of assumptions must be made, based on indoor/outdoor, humidity, wind, cycling, safety factors, and so forth. We recommend you consult a qualified engineer and have them work closely with the contractor, and Dyplast to help insure a properly designed, installed, and long-lasting insulation system. Thickness calculations may be performed using the 3E Plus ([3E-Plus Insulation Thickness Software](#)) software program that uses heat flow algorithms based on ASTM C680-95.